

Driveway Standards
for
Greene Township
Beaver County
Pennsylvania

The following Driveway Standards must be met for approval of new driveways within Greene Township. Contact the Roadmaster at the Greene Township Municipal Garage at 573-4612 between the hours of 9 AM and 3 PM, Monday through Friday, to arrange for an inspection. A minimum of 24 hours advanced notice must be given to the Roadmaster in order properly coordinate the inspection.

The attached text and diagrams demonstrate the requirements for driveway construction. If you are preparing a subdivision plan, approval will not be granted if these requirements cannot be met on ALL lots within the subdivision.

General Location Restrictions. Access driveways shall be permitted at locations in which:

1. sight distance is adequate to safely allow each permitted movement to be made into and out of the access driveway;
2. the free movement of normal highway traffic is not impaired;
3. the driveway will not create a hazard; and
4. the driveway will not create an area of undue traffic congestion on the highway.

Grade of Access Driveway. Grade of the access driveway shall be constructed in the following manner:

1. All driveways shall be constructed so as not to impair drainage within the right-of-way, alter the stability of the improved area, or change the drainage of adjacent areas.
2. Where a drainage ditch or swale exists, the permittee shall install an adequate drainage pipe under the driveway of at least 15 inches in diameter.
3. The side slopes of the driveway embankments within the right-of-way shall not be steeper than ten to one.
4. Grade requirements in uncurbed shoulders within the right-of-way shall conform to Figure 1.
5. Driveway material shall meet PaDOT standards and shall not run onto any areas of the right-of-way.
6. If there is a sight distance problem, left turns may be prohibited.
7. There will be no permit issued where safety is to be compromised.

Sight Distance Requirements. Conditions for sight distance shall be as follows:

1. Access driveways shall be located at a point within the property frontage limits which provides at least the minimum sight distance listed in the following table (1):

Table 1 - Safe Sight Distance for passenger cars and single unit trucks exiting from driveways onto two lane roads.

<u>Posted Speed Limit</u> (mph)	<u>Safe Sight Distance Left</u> (feet)	<u>Safe Sight Distance Right</u> (feet)
25	250	195
35	440	350
45	635	570
55	845	875

Note: Safe Sight Distance is measured from a vehicle ten feet back from the pavement edge. See Figure 2.

(1) Reference: Commonwealth of Pennsylvania, Pennsylvania Code, Title 67, Chapter 441, Access to and Occupancy of Highways by Driveways and Local Roads, 1982.

FIG 1

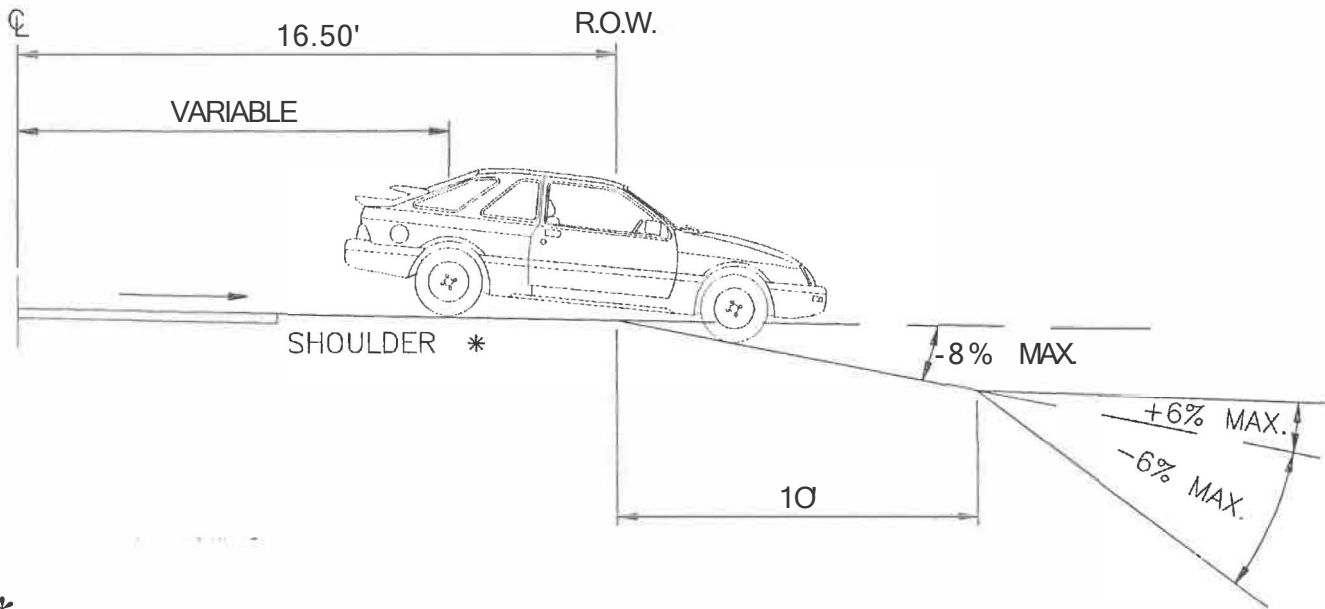

* EXTEND EXISTING SHOULDER TO RIGHT-OF-WAY (i.e. 16.50' FROM CENTER LINE OF ROAD). MAINTAIN SLOPE OF EXISTING SHOULDER, NEXT 10 FOOT SECTION SHOULD NOT EXCEED 8%.

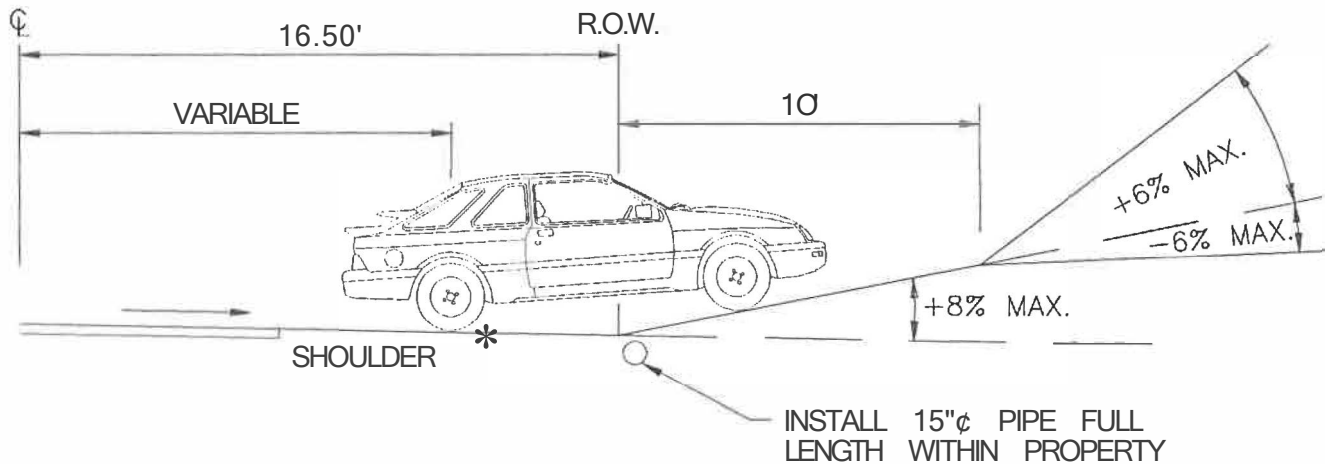

* EXTEND EXISTING SHOULDER TO RIGHT-OF-WAY (i.e. 16.50' FROM CENTER LINE OF ROAD). MAINTAIN SLOPE OF EXISTING SHOULDER, NEXT 10 FOOT SECTION SHOULD NOT EXCEED 8%.

(1) REFERENCE: Commonwealth of Pennsylvania, Pennsylvania Code, Title 67, Chapter 441, Access to and Occupancy of Highways by Driveways and Local Roads, 1982

Figure 1 - Grade Requirements

GREENE TOWNSHIP - DRIVEWAY STANDARDS

SCALE: N.T.S. S.O.No.20298-001-ARA
 DATE: JULY 1994 FILE: GREENE-1 DWG



MICHAEL BAKER JR., INC.
 Consulting Engineers
 BEAVER PENNSYLVANIA

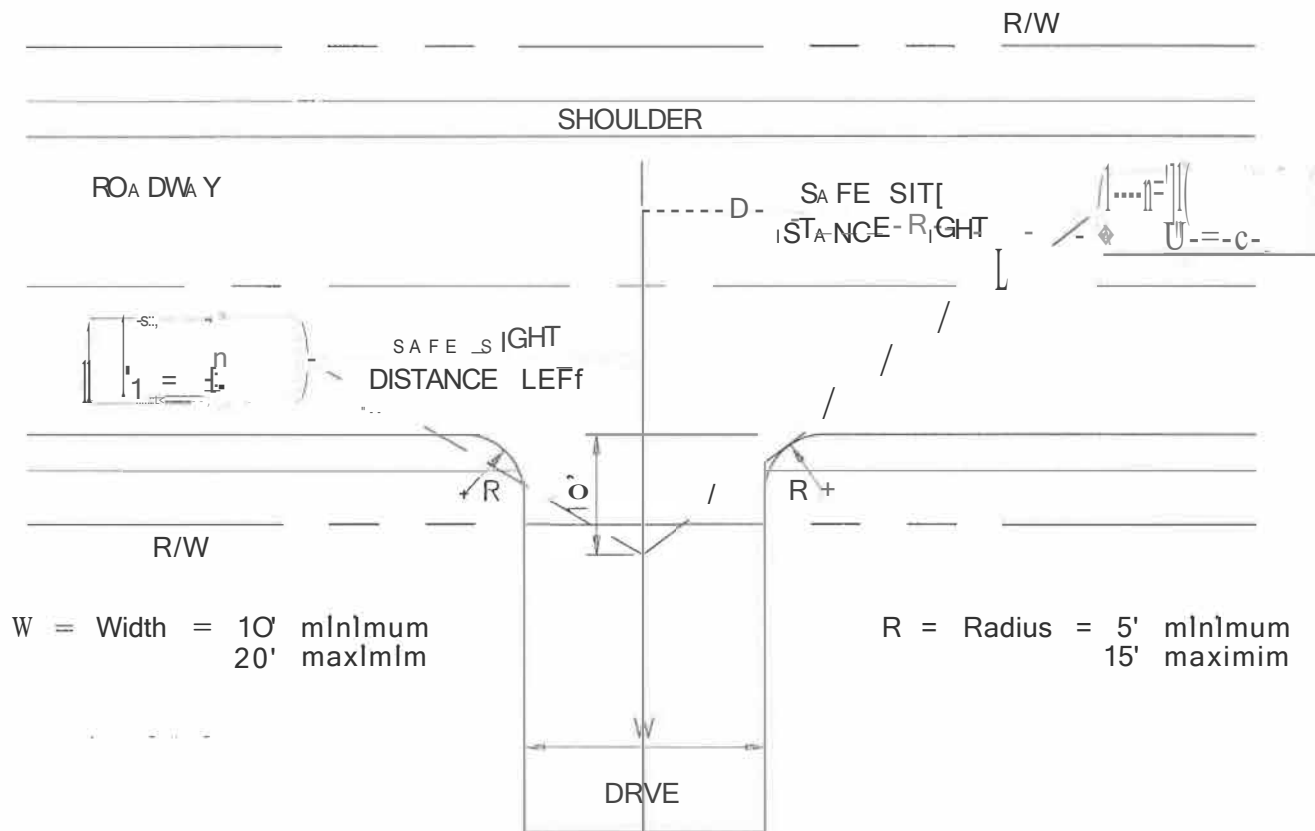

Table 1 - Safe Sight Distance for passenger cars and single unit trucks existing from driveways onto two lane roads. (1)

Posted speed Limit (mph)	Safe Sight Distance Left (feet)	Safe Sight Distance Right (feet)
25	250	195
35	440	350
45	635	570
55	845	875

Note: safe Sight Distance is measured from a vehicle ten feet back from the pavement edge. see Figure 2.

(1) REFERENCE: Commonwealth of Pennsylvania, Pennsylvania Code, Title 67, Chapter 441, Access to and Occupancy of Highways by Driveways and Local Roads, 1982

Figure 2 - Site Distance Requirements

GREENE TOWNSHIP - DRIVEWAY STANDARDS

SCALE: 1"=10'-0" T.S. S.O.No.20298-001-A RA

DATE: JULY 1994 FILE: GREENE-2.DWG



MICHAEL BAKER JR., INC.
Consulting Engineers
BEAVER PENNSYLVANIA